

PAT 6 - AREA & PERIMETER

Name: _____

Date: _____

1. The shaded area of the diagram below is a scale drawing of an outdoor play area.

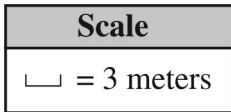
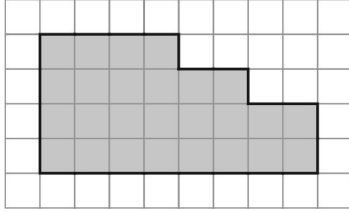

What is the least amount of fencing needed to completely surround the actual play area?

- A. 24 meters B. 26 meters C. 72 meters D. 78 meters
2. Alan received a package shaped like a rectangular prism. How many vertices does the package have?
- A. 4 B. 6 C. 8 D. 12
3. Four congruent right triangles are cut off the corners of a square. The diagram below shows the dimensions of the square and the congruent right triangles.

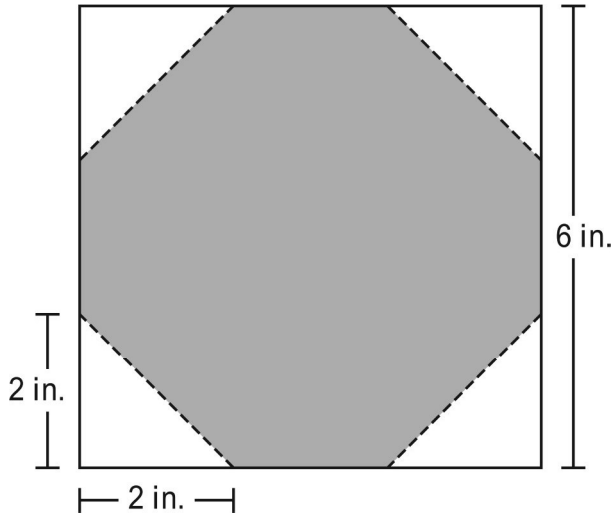

What is the area of the shaded part of the diagram?

- A. 18 sq.in. B. 20 sq.in. C. 28 sq.in. D. 34 sq.in.

4. Pascal had a rectangular piece of paper. He cut off a corner of the paper. The shape below is what was left.

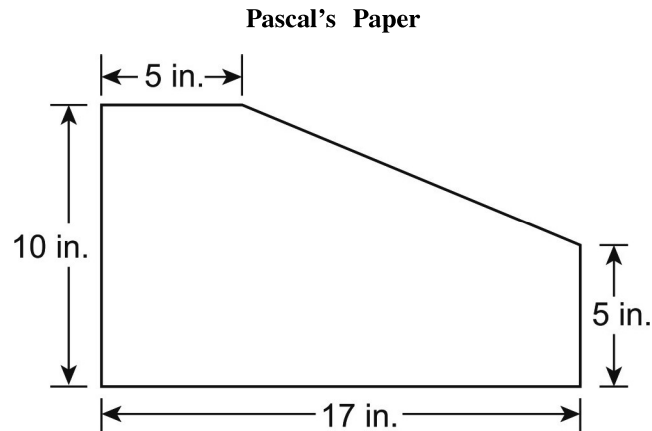

What is the area, in square inches, of the shape that was left?

- A. 50 square inches B. 110 square inches C. 140 square inches D. 170 square inches
5. Joann's garden plot is 5 feet by 6 feet. Joann decides to double the length and the width of the garden. How does the perimeter of her garden change?
- A. The perimeter is one and a half times larger than the perimeter of the original garden.
B. The perimeter is two times larger than the perimeter of the original garden.
C. The perimeter is three times larger than the perimeter of the original garden.
D. The perimeter is four times larger than the perimeter of the original garden.
6. Use the diagram below to answer the following question.

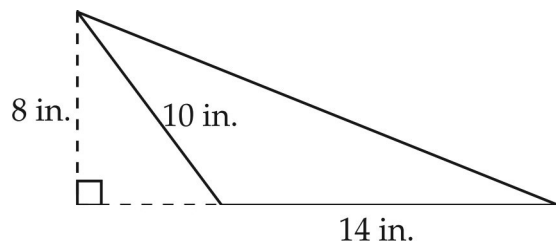

What is the area of the obtuse triangle?

- A. 32 in.^2 B. 40 in.^2 C. 56 in.^2 D. 70 in.^2
7. Paul has a container in the shape of a square pyramid. How many vertices does the container have?
- A. 4 B. 5 C. 6 D. 8

8. Bethany is going to play tennis with her friend. She brought a cylinder-shaped can of three tennis balls.

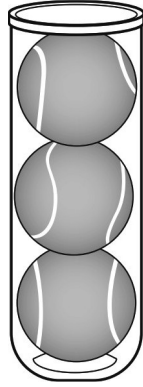

How are the dimensions of the cylinder most likely related to those of the tennis balls?

- A. The height of the can is 3 times the diameter of one tennis ball.
 - B. The volume of the three tennis balls is equal to the volume of the can.
 - C. The height of the can is equal to three times the radius of one tennis ball.
 - D. The circumference of the opening of the can is equal to the radius of one tennis ball.
9. The area of a right triangle is 24 square feet. A second right triangle has a base that is 2 times as long as the first triangle's base and a height that is 3 times as long as the first triangle's height.

What is the area of the second triangle?

- A. 48 square feet
- B. 72 square feet
- C. 144 square feet
- D. 864 square feet

10. A hexagonal prism is shown below.

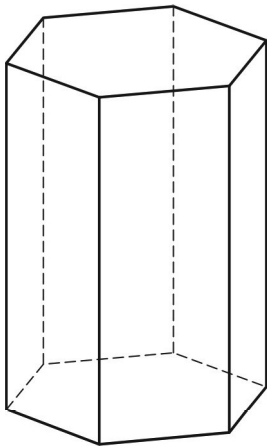

What is the total number of edges in a hexagonal prism?

11. The dimensions of a figure are shown below.

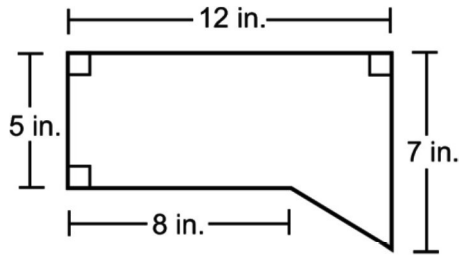

What is the total area of the figure?

- A. 60 square inches B. 64 square inches C. 68 square inches D. 84 square inches
12. Tamika made a model of a house, as shown below, by gluing together a cube and a square pyramid.

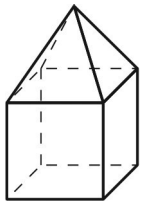

How many faces does the model of the house have?

- A. 4 B. 8 C. 9 D. 11
13. A trapezoid and some of its dimensions are shown below.

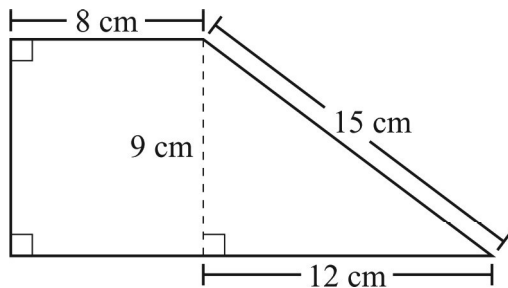

What is the perimeter of the trapezoid?

- A. 44 cm B. 52 cm C. 126 cm D. 180 cm
14. A rectangle has a length of $4\frac{1}{2}$ inches and a width of $2\frac{3}{4}$ inches.

What is the area of the rectangle, in square inches?

- A. $12\frac{3}{8}$ B. $12\frac{1}{4}$ C. $6\frac{2}{3}$ D. $6\frac{3}{8}$

15. Jacob is making a kite that has the dimensions shown below.

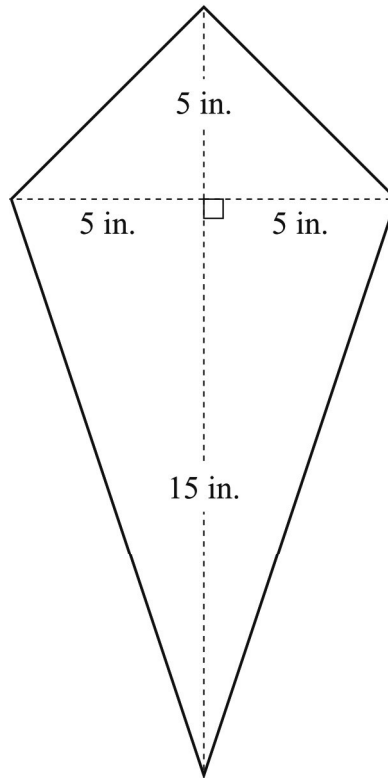

What is the area of Jacob's kite?

- A. 25 sq. in. B. 50 sq. in. C. 100 sq. in. D. 200 sq. in.
16. Elisa divided the staircase figure below into rectangles to help determine its area. All measurements are in millimeters.

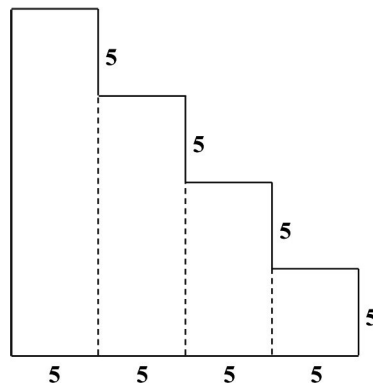

What is the total area of the figure?

- A. 150 square millimeters B. 200 square millimeters
C. 250 square millimeters D. 325 square millimeters

21. Tyron's garden is 2 feet by 3 feet. If he triples the length and the width, which statement is true?

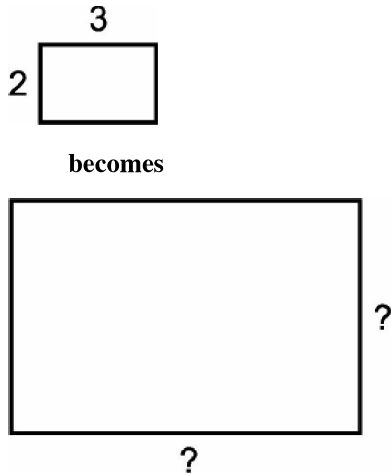

- A. The perimeter and the area are twice as big.
B. The perimeter triples and the area is nine times as big.
C. The perimeter triples and the area doubles.
D. The perimeter triples and the area triples.
22. A parallelogram and its dimensions are shown below.

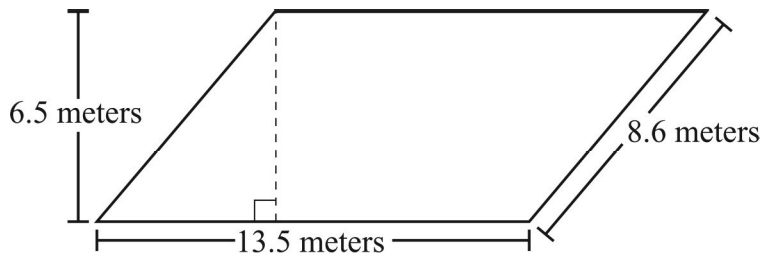

Which of the following is closest to the perimeter of the parallelogram?

- A. 22 meters B. 44 meters C. 88 meters D. 116 meters
23. Carolyn is building a picnic table in the shape of an octagon. Each side of the picnic table is 26 inches. What is the perimeter of the picnic table?
- A. 156 inches B. 208 inches C. 260 inches D. 676 inches
24. Which of the following measures could be 432 square inches?
- A. the width of a car B. the area of a doormat
C. the volume of a suitcase D. the perimeter of a classroom

25. The diagram below shows a pennant and some of its dimensions.

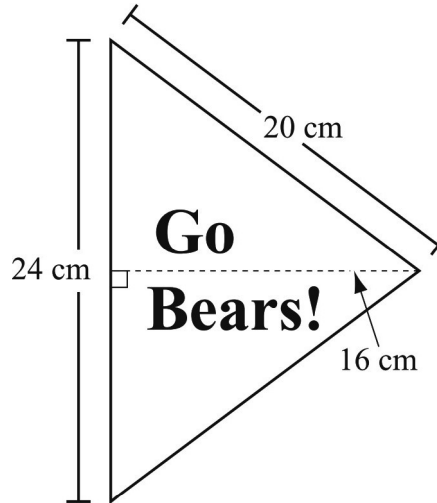

What is the area of the pennant?

- A. 192 cm^2 B. 240 cm^2 C. 384 cm^2 D. 480 cm^2

26. Students in Corey's class can sit in this tent to read. How many vertices does the tent have?

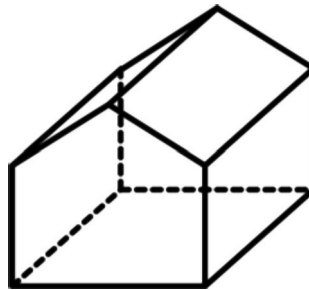

- A. 7 B. 9 C. 10 D. 15

27. The floor in Steve's room is shaped like a rectangle.

- It has an area of 168 square feet.
- It has a width of 12 feet.

What is the length of Steve's room?

- A. 14 feet B. 28 feet C. 72 feet D. 84 feet

28. Which shapes have the same area?

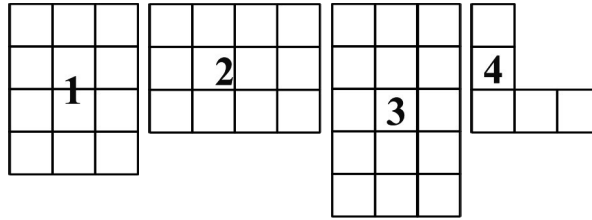

- A. 1 and 2 B. 2 and 3 C. 4 and 5 D. 2 and 4

29. Triangles A and B are congruent.

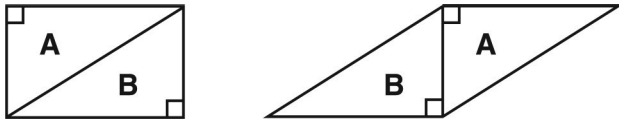

If the area of the rectangle is 7 square units, what is the area, in square units, of the parallelogram?

- A. 3.5 B. 7 C. 14 D. 18.5

30. Study the shapes below.

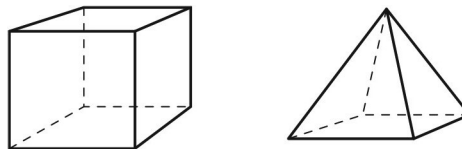

Which figure is made by combining the 2 shapes?

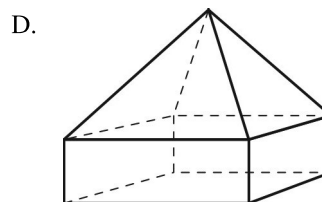
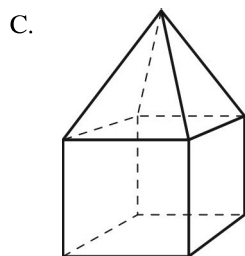
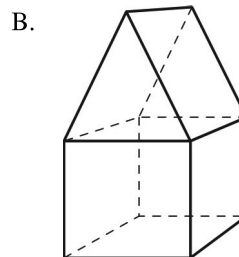
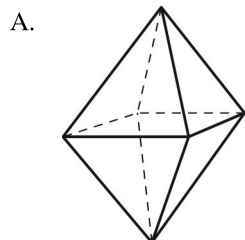

31. A triangle has a base of 4 cm and a height of 5 cm. What is the area of a rectangle with the same base and height?

- A. 10 cm² B. 18 cm² C. 20 cm² D. 40 cm²

32. Which unit is appropriate for measuring the area of the bottom of a pan?
- A. inch B. foot C. square inch D. cubic foot
33. Two tetrahedra are congruent. One tetrahedron is glued to the other so that the glued faces of the two tetrahedra completely cover each other, producing a new polyhedron. How many faces does the new polyhedron have?
- A. 6 B. 7 C. 8 D. 9
34. A triangle has an area of 16 square inches and a height of 4 inches. What is the length of the base?
- A. 4 inches B. 8 inches C. 12 inches

35. Larry used construction paper to make a cube and 6 square pyramids. Each pyramid is the same size. The diagram below shows the cube and the 6 square pyramids.

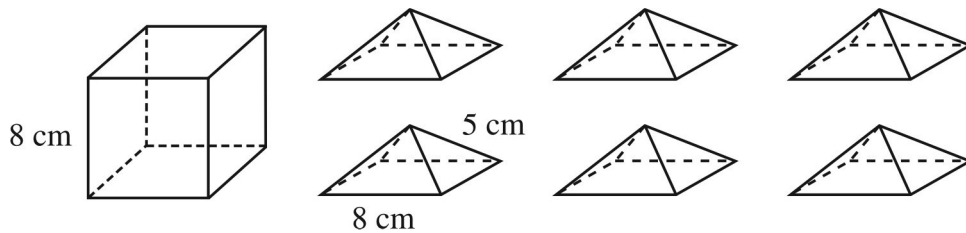

Larry used the cube and the square pyramids to create a new figure. He glued the base of each pyramid to a different face on the cube, making sure the edges were aligned. What is the total number of faces on the new figure Larry created?

- A. 9 faces B. 11 faces C. 24 faces D. 30 faces
36. My flower garden is a square. It has an area of 1600 ft^2 . What is the length of one side of my garden?
- A. 40 feet B. 160 feet C. 6400 feet D. 1,560,000 feet
37. A rectangular rug has a perimeter of 26 meters. Which of the following could be true about the rug? L is for length and W is for width.
- A. $L = 13 \text{ m}, W = 2 \text{ m}$ B. $L = 6.5 \text{ m}, W = 5 \text{ m}$ C. $L = 5.2 \text{ m}, W = 5 \text{ m}$ D. $L = 8 \text{ m}, W = 5 \text{ m}$

38. Brad created the design for a porch as shown below.

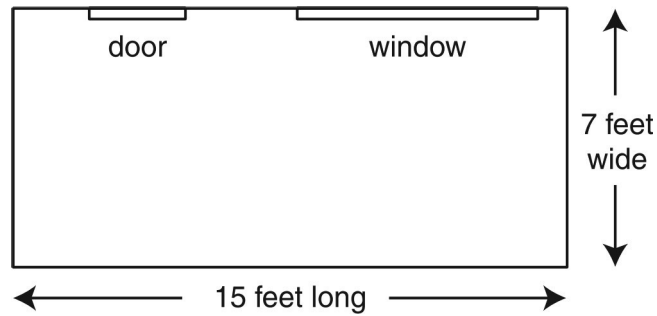

Brad decided to change the design by making the width of the porch twice as large as it was in the first design. Which statement is true about the new design?

- A. It increases the perimeter of the porch by 7 feet.
- B. It increases the area of the porch by 7 square feet.
- C. It doubles the perimeter of the porch.
- D. It doubles the area of the porch.

39. Madelyn had a square piece of cardboard that was 10 inches in length. She cut one 3-inch square from each corner, as shown below.

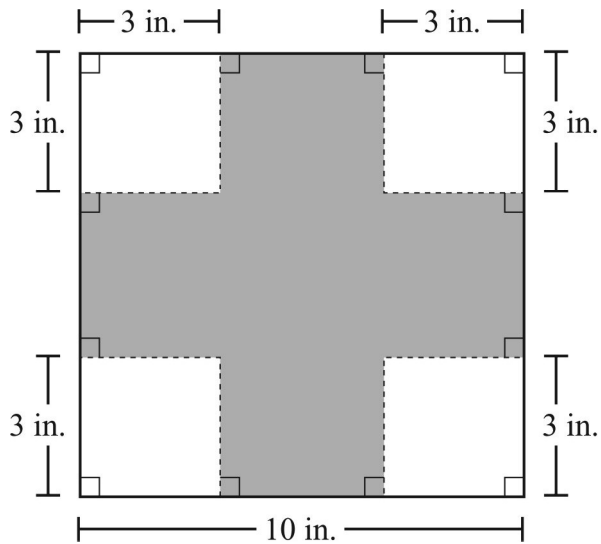

The shaded part represents the remaining cardboard. What is the area of the remaining cardboard?

- A. 36 sq. in.
- B. 48 sq. in.
- C. 64 sq. in.
- D. 80 sq. in.

40. Which statement is true about *all* prisms?

- A. The number of edges is an odd number.
- B. The number of edges is an even number.
- C. The number of vertices is an odd number.
- D. The number of vertices is an even number.

41. The area of a right triangle is 24 square units. Which of the following sets of numbers could represent the side lengths, in units, of the right triangle?
- A. 3, 8, and 9 B. 4, 6, and 8 C. 6, 8, and 10 D. 4, 12, and 15
42. If the length of a rectangle is doubled, what will happen to its area?
- A. The area will be the same. B. The area will be twice as large.
C. The area will be three times as large. D. The area will be four times as large.
43. Robert needs to determine the area of his garden. The garden is 12 feet long and 9 feet wide. Which statement explains how Robert can correctly calculate the area of his garden?
- A. Find the sum of 12 and 9.
B. Multiply 1 by 2, multiply 1 by 9, and find the sum of the products.
C. Multiply 1 by 9, multiply 2 by 9, and find the sum of the products.
D. Multiply 10 by 9, multiply 2 by 9, and find the sum of the products.
44. Look at the figure below.

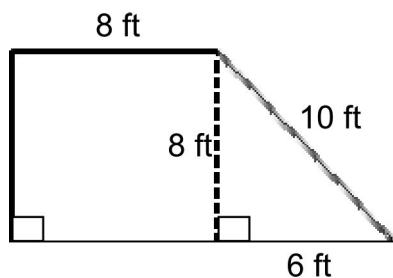

What is the perimeter of the figure?

- A. 32 ft B. 40 ft C. 48 ft D. 94 ft
45. Trevor had a field 10 feet long and 5 feet wide. Trevor gave Mike one half of his field. How much field did Mike get?
- A. 50 ft^2 B. 25 ft^2 C. 15 ft^2 D. 7.5 ft^2
46. A triangle has two congruent sides. The perimeter of the triangle is 50 centimeters. Only one side of the triangle has a length of 22 centimeters. What is the length of each of the congruent sides?
- A. 14 centimeters B. 22 centimeters C. 28 centimeters D. 72 centimeters

47. A regular hexagon has sides of 3.7 meters. What is the perimeter of the hexagon?

- A. 29.6 meters B. 22.2 meters C. 18.5 meters D. 13.7 meters

48. Which of the following represent rectangular prisms?

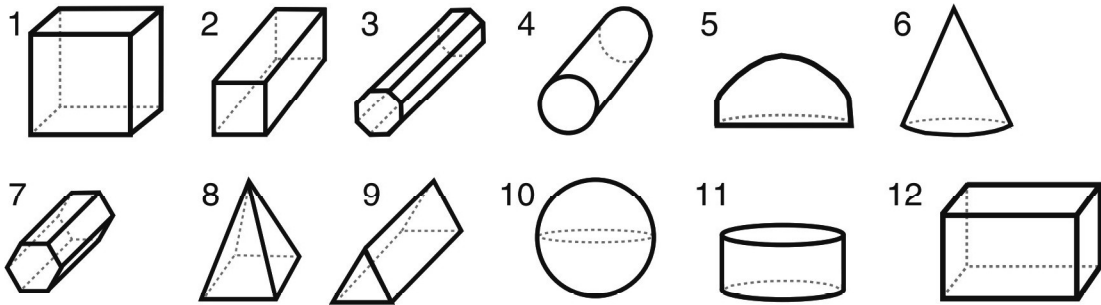

- A. 2, 9, 11 B. 3, 4, 7 C. 5, 6, 10 D. 1, 2, 12

49. Kwame drew the triangle shown in the diagram below.

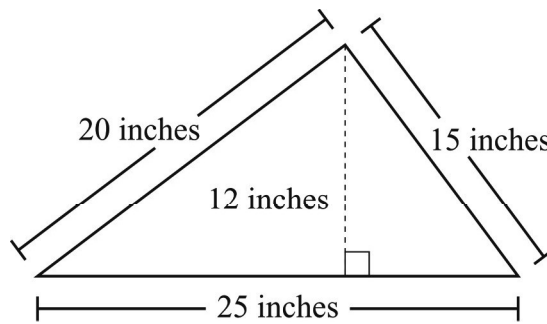

Based on the dimensions in the diagram, what is the area of Kwame's triangle?

- A. 150 square inches B. 250 square inches C. 300 square inches D. 375 square inches

50. The length of the rectangular flag in front of a courthouse is 18 feet. The width of the flag is 14 feet.

What is the perimeter of the flag?

$$P = 2l + 2w$$

- A. 32 feet B. 36 feet C. 40 feet D. 64 feet

51. Look at the figure.

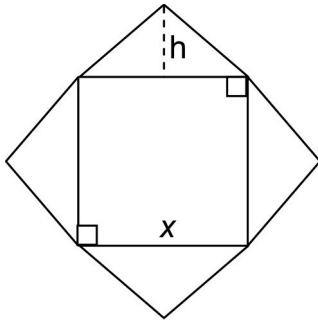

Which process can be used to find the total area of the figure?

- A. find x^2 and multiply that by 3
 - B. multiply one-half of x by h and add that to x^2
 - C. find x^2 and add that to two times x multiplied by h
 - D. multiply x by h and then multiply that answer by 2
52. Alex drew a square picture measuring 8 inches on each side.

He put a 2-inch border around the picture.

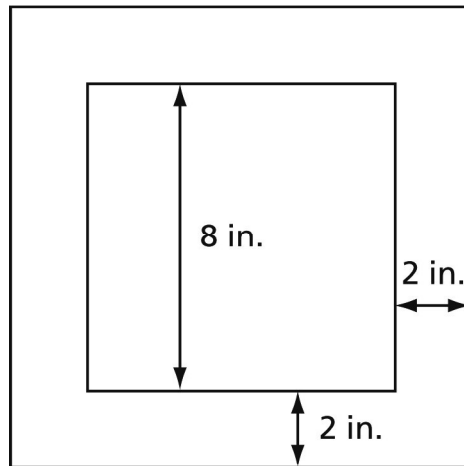

What is the area of the border?

- A. 8 square inches
 - B. 36 square inches
 - C. 80 square inches
53. A rectangular park has a perimeter of 80 meters. One side measures 16 meters. What are the lengths of the other three sides?
- A. 16 meters, 5 meters, 5 meters
 - B. 16 meters, 24 meters, 24 meters
 - C. 16 meters, 48 meters, 48 meters
 - D. 24 meters, 20 meters, 20 meters

54.

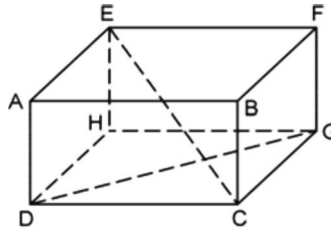

Given the right rectangular prism, which of the following statements must be true?

- A. $\overline{EC} \cong \overline{DG}$ B. $\overline{DH} \cong \overline{GF}$ C. $\angle CDG \cong \angle CEH$ D. $\overline{HG} \cong \overline{AB}$

55. Yoshi is designing a monument that has a triangular base. He drew $\triangle JKR$ to represent the base of the monument, as shown in the diagram below.

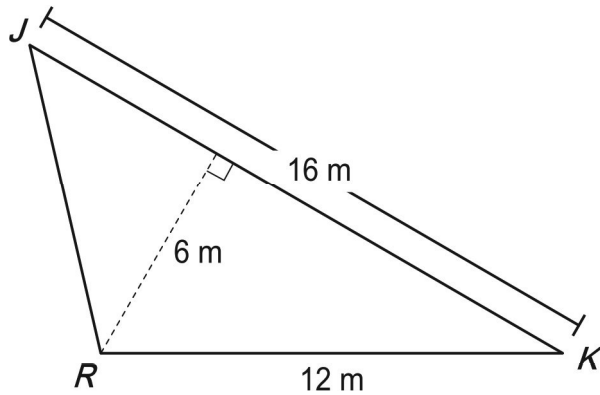

Based on the measurements in the diagram, what is the area, in square meters, of $\triangle JKR$?

56. A triangle is shown below.

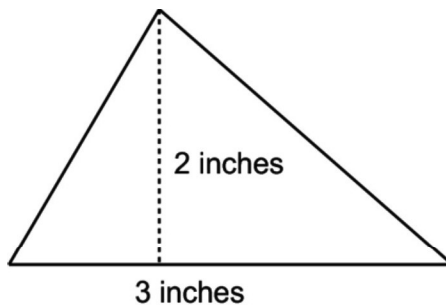

What happens to the area of this triangle when both its base and its height are tripled?

- A. The area is $\frac{1}{3}$ times larger. B. The area is 3 times larger.
 C. The area is 6 times larger. D. The area is 9 times larger.

57. Look at the figure below.

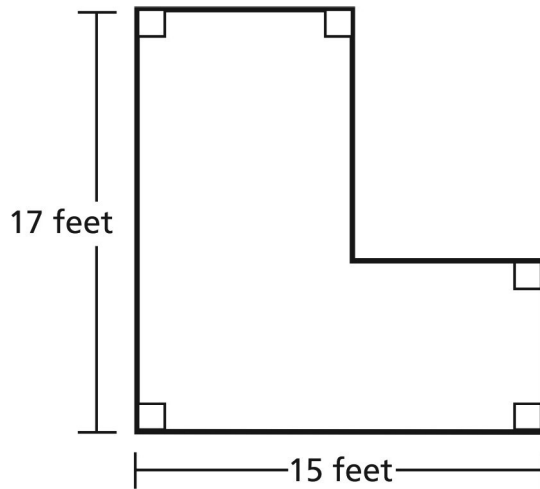

What is the perimeter, in feet, of the figure?

- A. 32 feet B. 64 feet C. 96 feet D. 128 feet

58. The figure below shows a diagram of a reading room.

Reading Room

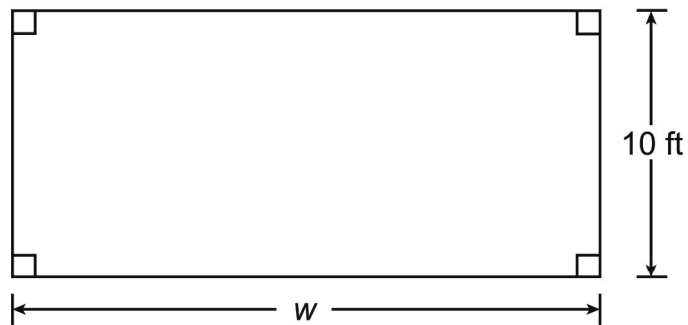

The perimeter of the reading room is 60 feet (ft). What is the width, w , of the reading room?

- A. 6 ft B. 12 ft C. 20 ft D. 50 ft

59. The figure below is a rectangular prism. Which of the following edges is perpendicular to face BFGC?

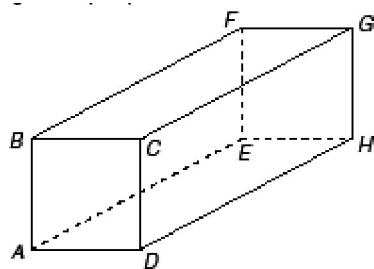

- A. \overline{AB} B. \overline{AE} C. \overline{DH} D. \overline{BF}

60. Which statement about the prism below is true?

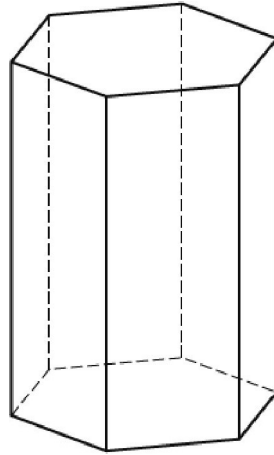

- A. The number of faces is more than the number of vertices.
- B. The number of edges is less than the number of vertices.
- C. The number of vertices is more than the number of faces.
- D. The number of vertices is more than the number of edges.

61. Use the picture below to answer the question that follows.

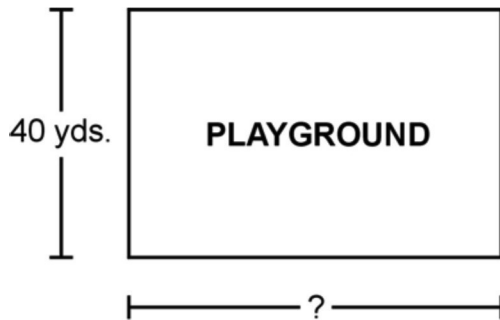

The area of the rectangular playground above is 2,400 square yards, and the width is 40 yards. What is the length of the playground?

- A. 40 yards
- B. 60 yards
- C. 1,160 yards
- D. 2,360 yards

62. The trapezoid below can be divided into 3 identical triangles.

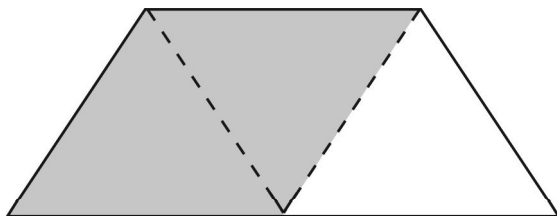

If the area of the shaded parallelogram is 16 cm^2 , what is the area of the trapezoid?

- A. 8 cm^2
- B. 24 cm^2
- C. 32 cm^2
- D. 48 cm^2

63. What is h , the height of the parallelogram represented below, if its area is 91 square centimeters?

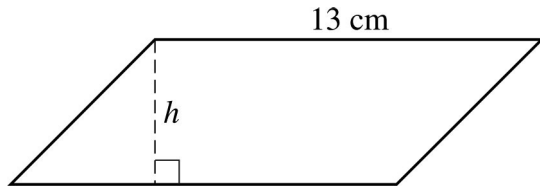

- A. 7 cm B. 9 cm C. 11 cm D. 15 cm

64. Triangles ABC and DEF are similar. The lengths of the sides of $\triangle DEF$ are 3 times the lengths of the corresponding sides of $\triangle ABC$. How do the areas of the triangles compare?

- A. The area of $\triangle DEF$ is 3 times the area of $\triangle ABC$. B. The area of $\triangle DEF$ is 4 times the area of $\triangle ABC$.
C. The area of $\triangle DEF$ is 6 times the area of $\triangle ABC$. D. The area of $\triangle DEF$ is 9 times the area of $\triangle ABC$.

65. What is the perimeter of the figure below?

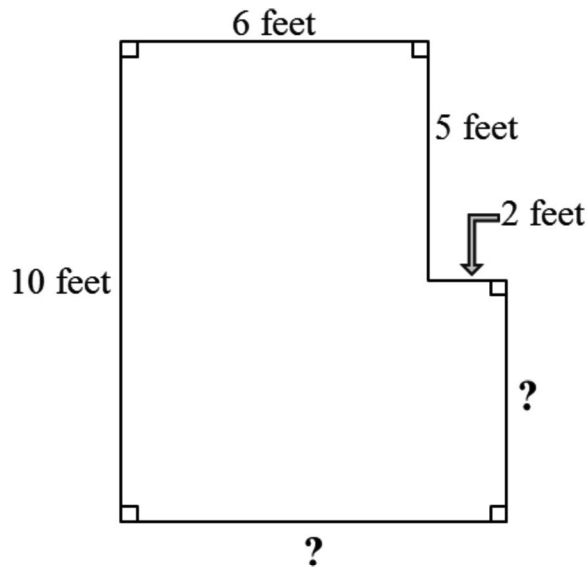

- A. 36 feet B. 28 feet C. 23 feet D. 13 feet

66. Donnie wants to enlarge a photograph that measures 3 inches by 5 inches. If both dimensions are doubled, what happens to the area of the photograph?

- A. It is doubled. B. It is multiplied by 4. C. It remains the same. D. It is multiplied by 8.

67. Which statement about a triangular prism is true?

- A. It has exactly 4 faces. B. It has exactly 5 faces.
C. It has exactly 6 edges. D. It has exactly 8 edges.

68. Sara pitched a tent in her backyard.

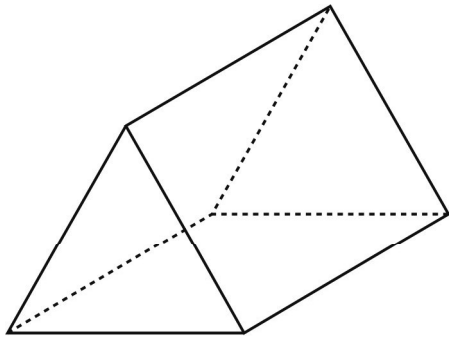

How many faces does Sara's tent have?

- A. 3 faces B. 5 faces C. 6 faces D. 9 faces

69. A trapezoid and some of its dimensions are shown below.

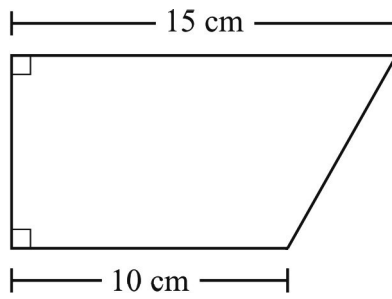

The area of the trapezoid is 100 square centimeters.

What is the height of the trapezoid?

- A. 2 cm B. 4 cm C. 8 cm D. 10 cm

70. Look at these solid geometric figures.

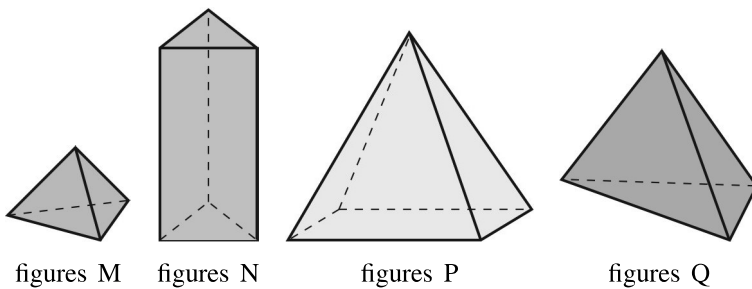

Which solid geometric figures are triangular pyramids?

- A. figures M and P B. figures M, N, and P C. figures M and Q D. figures M, N, and Q