

Name: _____

Date: _____

1. Which operation should be performed first in the expression

$$18 - 2 + 5 \times (16 + 66 \div 2)?$$

- A. $2 + 5$ B. 5×16 C. $16 + 66$ D. $66 \div 2$

2. Which expression has a value of 18?

- A. $[(3 \times 4) - (2 \times 5)] + 1$ B. $3 + 4 + [(2 \times 5) + 1]$ C. $3 + [(4 \times 2) + (5 \times 1)]$ D. $3 \times [(4 \times 2) - 5] - 1$

3. What is the simplified form of the expression below?

$$4 \times 5 + 2 \div 2$$

- A. 11 B. 14 C. 21 D. 24

4. Mary correctly used the order of operations to answer the following problem:

$$20 - 8 \cdot 4 \div 2 + 6$$

What is Mary's answer?

- A. 0 B. 6 C. 10 D. 30

5. Use the expression below to answer the question.

$$3 \times [(2 \times 6 - 5) + (8 \div 4)] - 1$$

What is the value of the expression?

- A. 9 B. 11 C. 26 D. 32

6. Which of the following expressions has the *greatest* value?

- A. $(6 + 6) \cdot 2 \div 3 - 1$ B. $6 + 6 \cdot 2 \div 3 - 1$ C. $6 + 6 \cdot 2 \div (3 - 1)$ D. $6 + 6 \cdot (2 \div 3 - 1)$

7. Compute:

$$12 \div 3 \times 4 - 1 + 6 \div 3$$

- A. 2 B. 7 C. 14 D. 17

8. Which pair of parentheses can be removed without changing the value of this expression?

$$(1 + 2) \times (6 - 3) + (5 \times 8) \div (9 - 4)$$

- A. parentheses around $1 + 2$
- B. parentheses around $6 - 3$
- C. parentheses around 5×8
- D. parentheses around $9 - 4$

9. Look at the figure below.

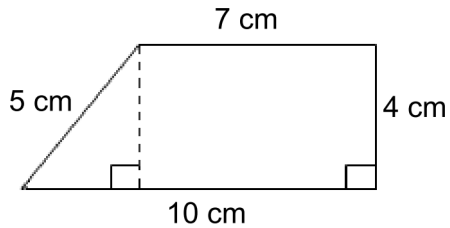

What is the total area of the figure?

- A. 26 cm^2
- B. 34 cm^2
- C. 40 cm^2
- D. 68 cm^2

10. Mariatu drew the figure shown on the grid below.

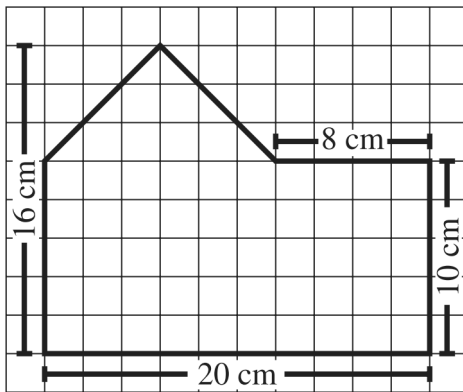

What is the area of the entire figure?

- A. 320 cm^2
- B. 236 cm^2
- C. 200 cm^2
- D. 72 cm^2

11.

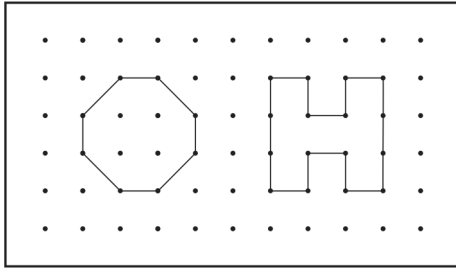

Which statement is true about the two polygons?

- A. They have equal areas but different perimeters.
- B. They have equal perimeters but different areas.
- C. They have equal areas and equal perimeters.
- D. They have different areas and different perimeters.

12. A trapezoid and its dimensions are shown below.

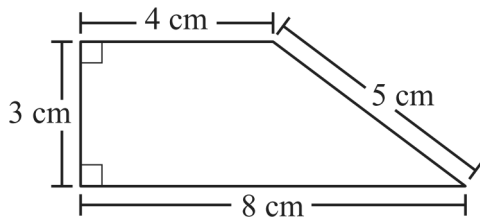

What is the area of the trapezoid?

- A. 12 cm^2
- B. 18 cm^2
- C. 20 cm^2
- D. 24 cm^2

13. This drawing shows the city boundaries of Dalmar.

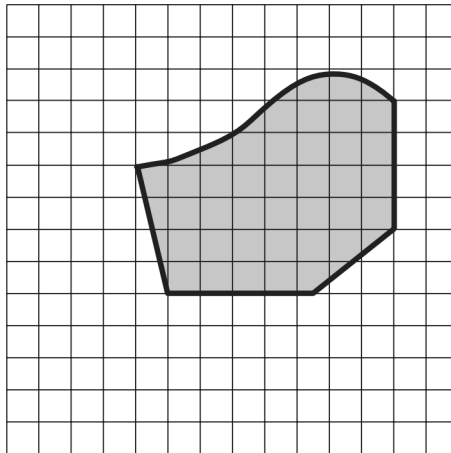

Estimate the area inside the city boundaries from the scale diagram above. Each square equals one square mile.

- A. 10 square miles
- B. 20 square miles
- C. 30 square miles
- D. 40 square miles

14. What are 2 factors that 15 and 24 have in common?

- A. 1 and 3
- B. 5 and 8
- C. 3 and 6
- D. 5 and 12

15. Which of the following lists *all* the factors of 56?

A. 1, 4, 6, 7, 8, 9, 16, 56

B. 1, 2, 4, 7, 8, 14, 28, 56

C. 1, 2, 28, 56

D. 1, 56

16. Which diagram represents the prime factorization of 36?

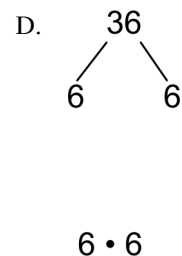
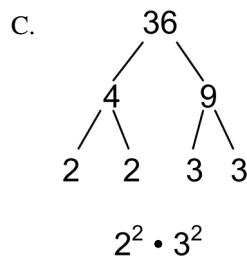
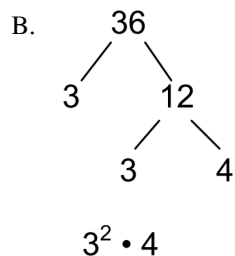
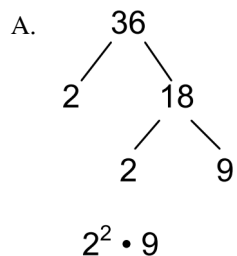

17. What is the prime factorization of 200?

A. $2^3 \times 5^2$

B. $2^2 \times 5^3$

C. $2^5 \times 5^2$

D. $2^5 \times 5^3$

18. What is the prime factorization of 45?

A. $2^3 \times 5$

B. $3^2 \times 5$

C. $5^2 \times 3$

D. $5^2 \times 9$

19. What is the prime factorization of 12?

A. $2^2 \times 3$

B. $2^2 \times 3^2$

C. 4×3

D. 1×2

20. Which number is

- a multiple of 3,
- a factor of 42, and
- odd?

A. 6

B. 9

C. 14

D. 21

21. Which number fits *all* of these clues?

- a multiple of 3
- an even number
- a multiple of 8
- not a multiple of 9

A. 48

B. 54

C. 63

D. 72

22. Which parallelogram is congruent to parallelogram $JKLM$?

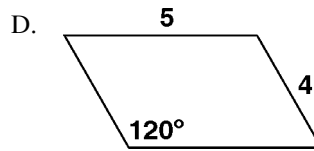
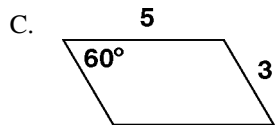
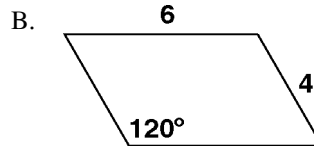
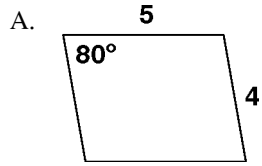
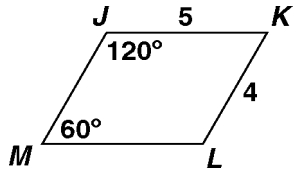

23. Which figure contains two congruent triangles?

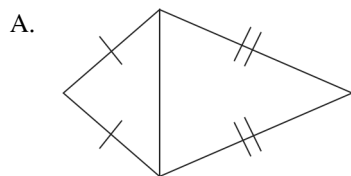

Quadrilateral

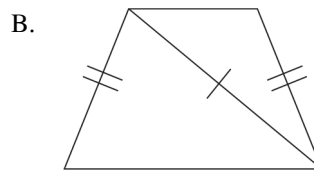

Trapezoid

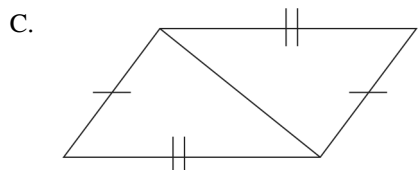

Parallelogram

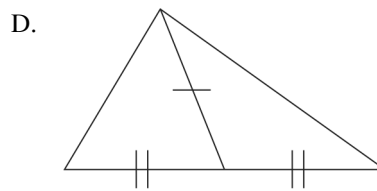

Triangle

24. Kyle made the figure below with his counters.

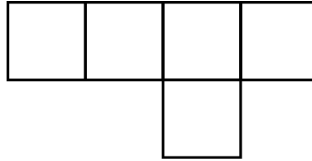

Which of these is congruent to Kyle's figure?

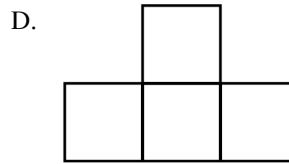
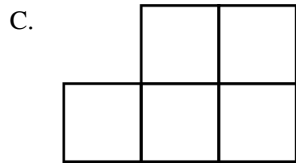
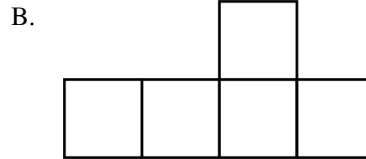
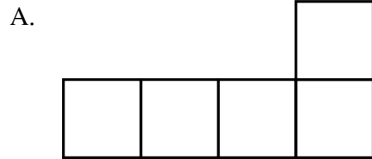

25. Which pair of rectangles in the figure appear to be congruent?

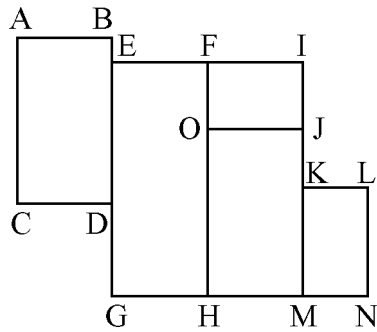

- A. ABCD and EFGH B. ABCD and OJHM C. EIOJ and KLMN D. EFGH and KLMN

26.

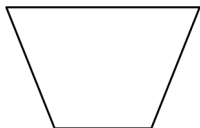

Which figure is congruent to the figure above?

A.

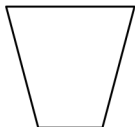

B.

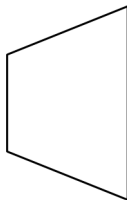

C.



D.

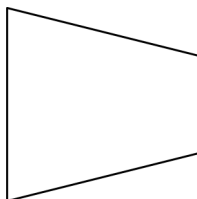

27. Which figure is divided into 4 congruent shapes?

A.

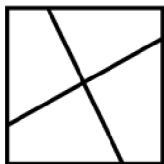

B.

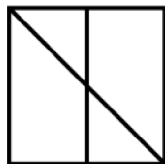

C.

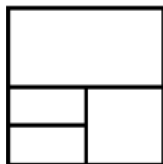

D.

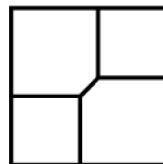

28. A triangular tile is shown.

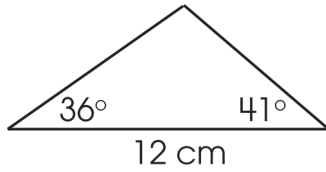

Patrick needs another tile that is congruent to this tile for the design on his kitchen wall.

Which tile is congruent to the original tile?

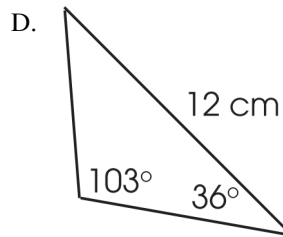
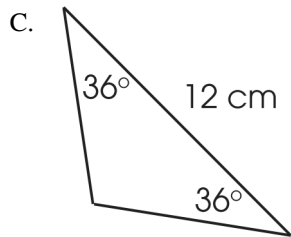
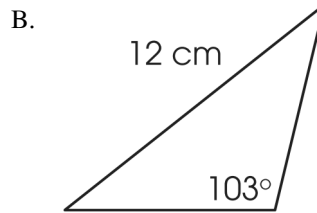
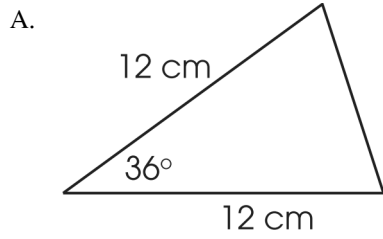

29. Look at the figures below.

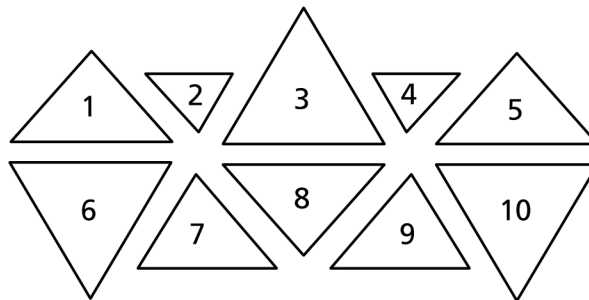

Which of these figures appear to be congruent?

A. 1 and 6

B. 3 and 9

C. 5 and 8

D. 7 and 2

30. On the grid below, points Q , R , and S represent three vertices of a rectangle.

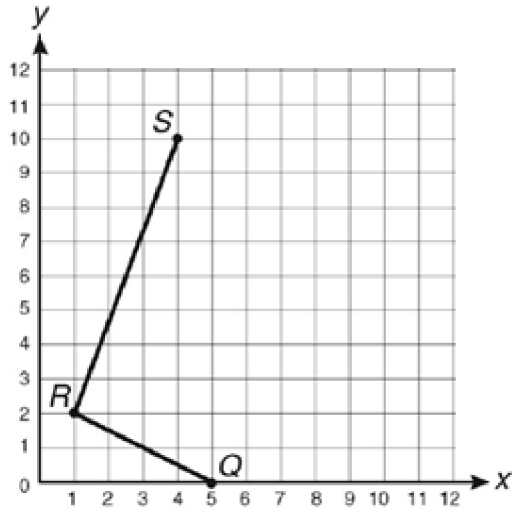

What are the coordinates of point T , the vertex that will complete rectangle $QRST$?

- A. (7, 8) B. (8, 7) C. (8, 8) D. (8, 9)

31.

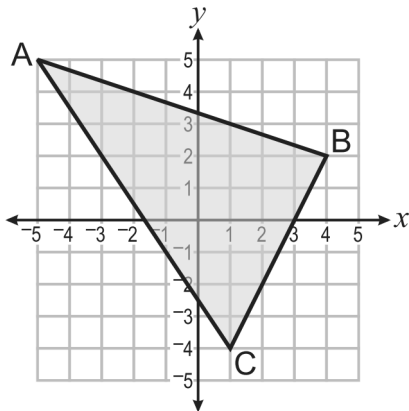

Which of the following are coordinates of a point located on a side of triangle ABC ?

- A. (0, 3) B. (-3, 2) C. (3, 1) D. (-2, 2)

32. In the figure below, $\triangle ABC$ is a right triangle and $m\angle A = 40^\circ$.

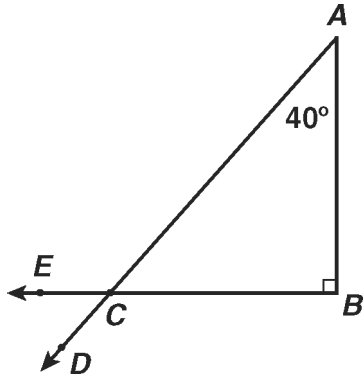

What is $m\angle ECD$?

- A. 40° B. 50° C. 130° D. 140°

33. What is $m\angle x$?

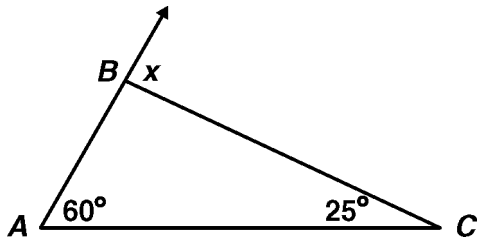

- A. 35° B. 60° C. 85° D. 95°

34. What is $m\angle 1$?

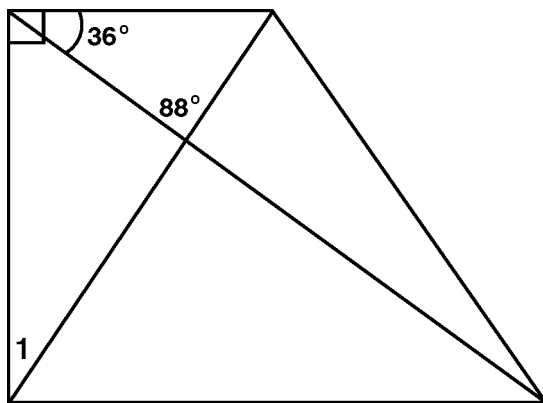

- A. 34° B. 56° C. 64° D. 92°

35. A triangle is a right triangle if the lengths, a , b , and c , of its three sides satisfy the following equation:

$$a^2 + b^2 = c^2$$

Which of the following is a right triangle?

- A. a triangle with sides measuring 13, 15, and 19 B. a triangle with sides measuring 17, 25, and 36
C. a triangle with sides measuring 20, 21, and 29 D. a triangle with sides measuring 18, 23, and 41

36. Intersecting sidewalks surround a playground shaped like a quadrilateral, as shown in the diagram below.

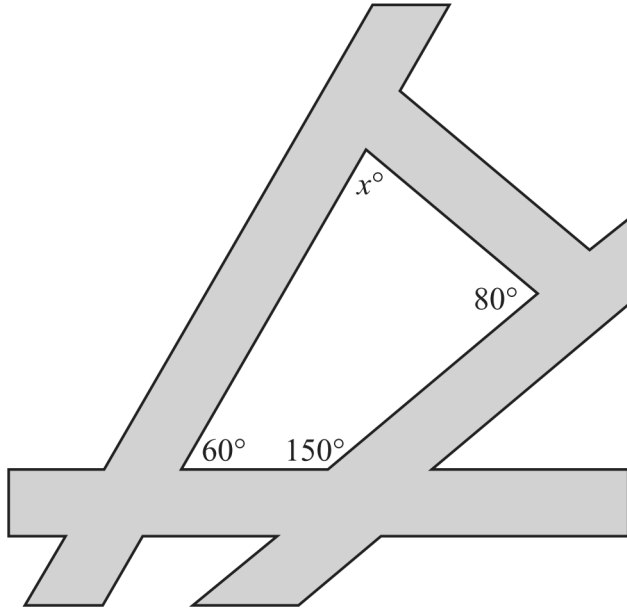

Based on the angle measures in the diagram, what is the value of x ?

- A. 70 B. 80 C. 120 D. 150

37. In the drawing, what is the measure of angle y ?

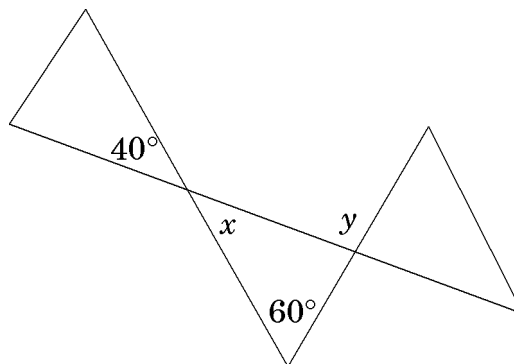

- A. 40 B. 60 C. 80 D. 100

38. The bus taking Mr. Scott's class on a field trip had a flat tire on the way to the zoo.

Class Field Trip to the Zoo

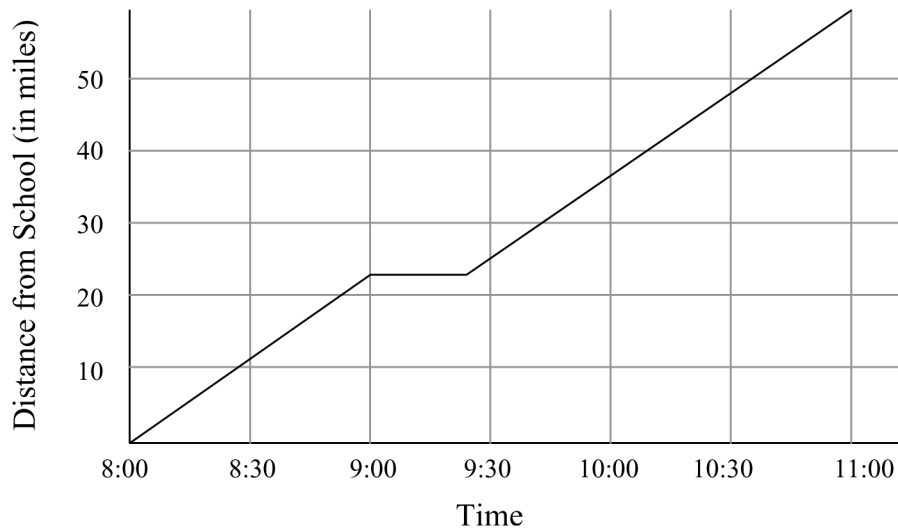

Based on the graph, approximately when did the bus tire go flat?

- A. 8:00 – 8:30 B. 9:00 – 9:30 C. 9:30 – 10:00 D. 10:30 – 11:00

39. Regina's piano teacher kept this record of Regina's progress on a song she is memorizing.

Piano Practice

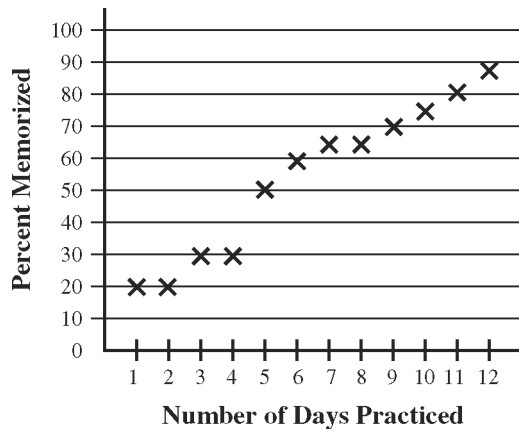

How many days of practice did it take for Regina to memorize half of the song?

- A. 4 B. 5 C. 6 D. 8

40. Crater Lake's 33-mile Rim Drive is popular with cyclists. The graph below shows the elevation change between key points of interest along Rim Drive.

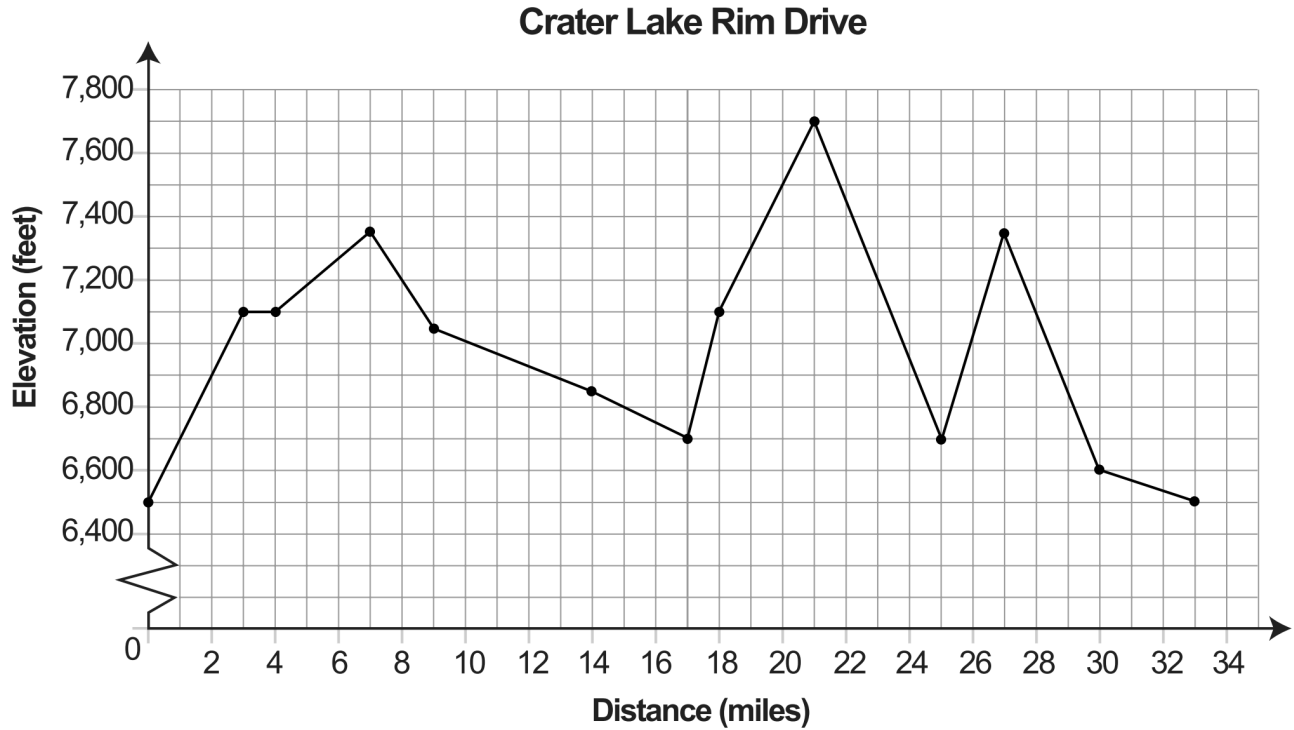

According to this graph, how many miles of Rim Drive are downhill?

41. Use the graph below to answer the question that follows.

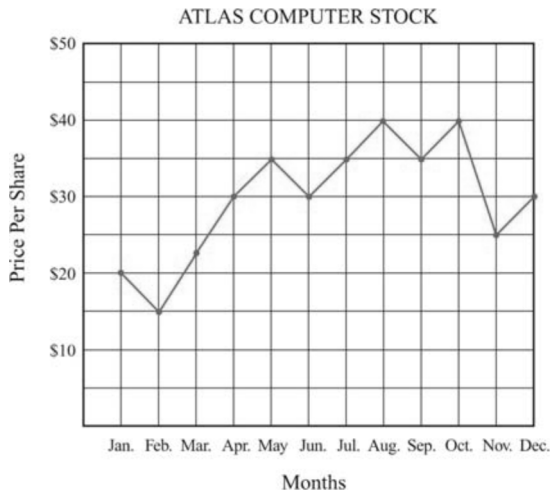

If Ginny bought 100 shares of Atlas Computer stock in February and sold it in October, what was her profit?

42. For a science project, Antoine recorded the height of a bean plant he was growing. After the plant sprouted, he measured it each day for two weeks. The graph below displays his data.

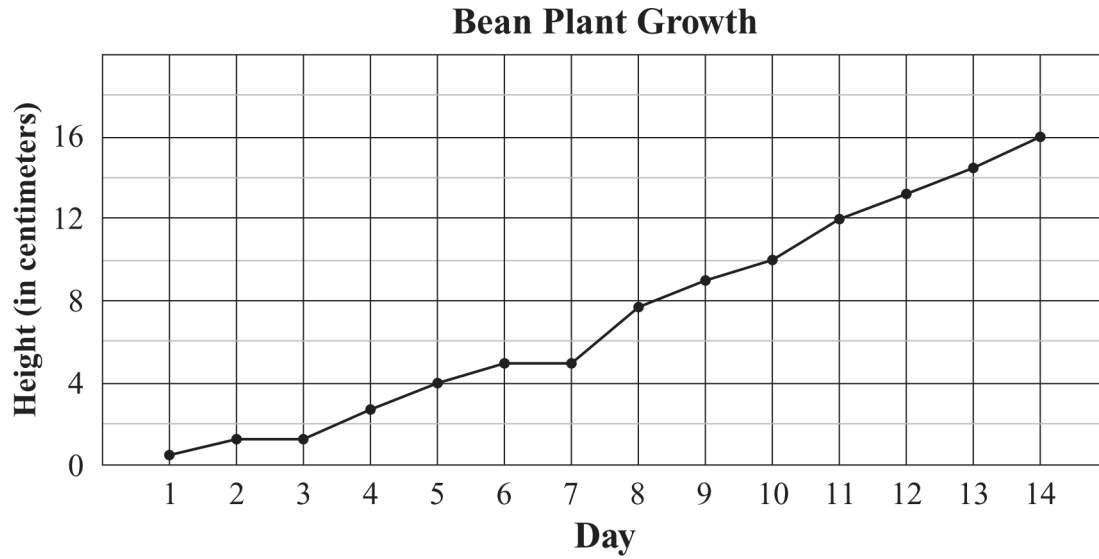

Which of the following is closest to the number of centimeters the bean plant grew from day 7 to day 14?

- A. 7 centimeters B. 9 centimeters C. 11 centimeters D. 16 centimeters

43. What was the lowest hourly temperature recorded at the 1,000-foot elevation?

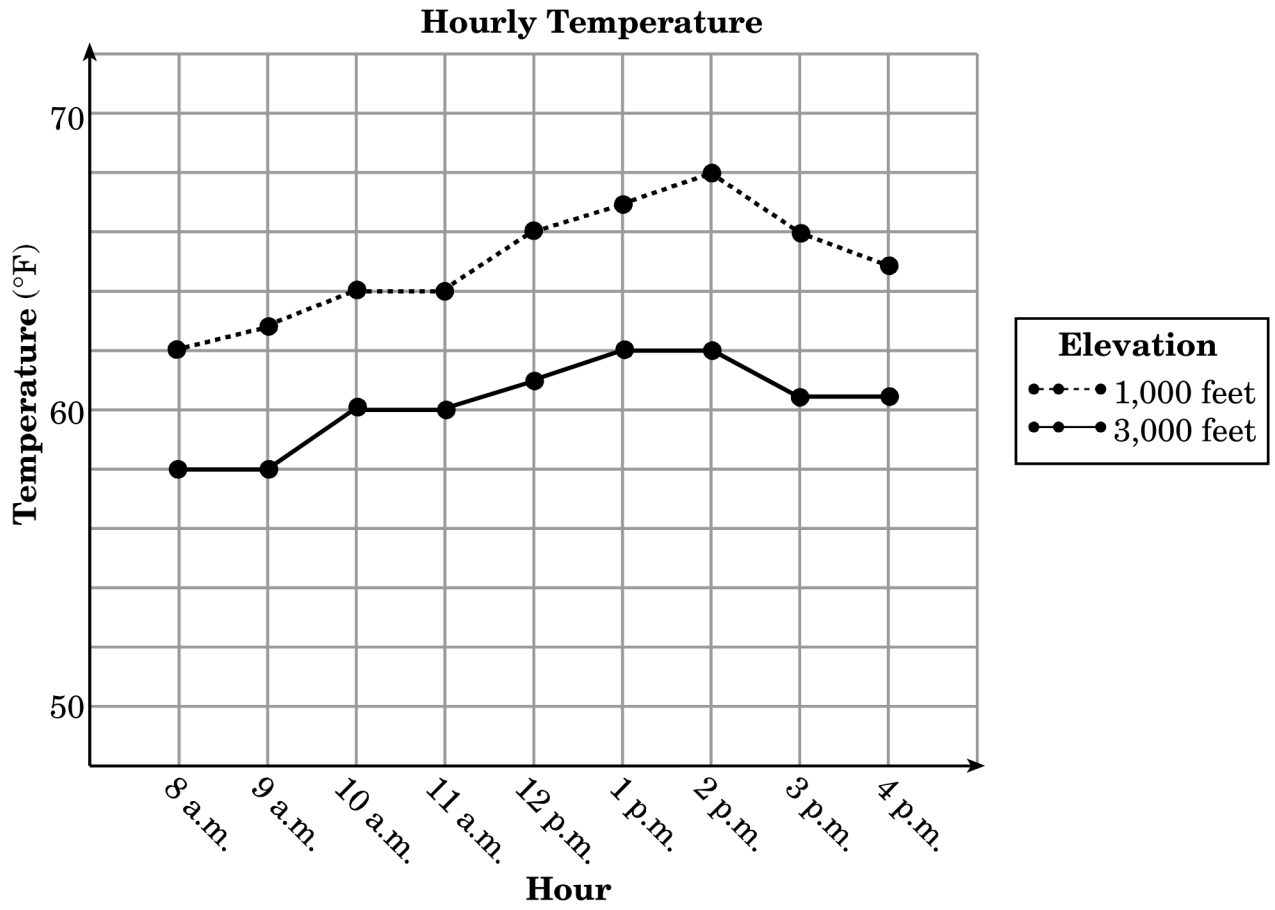

A. 54°F

B. 58°F

C. 61°F

D. 62°F

44. The graph below shows the temperatures at Keung’s house from 6:00 am to 10:00 am.

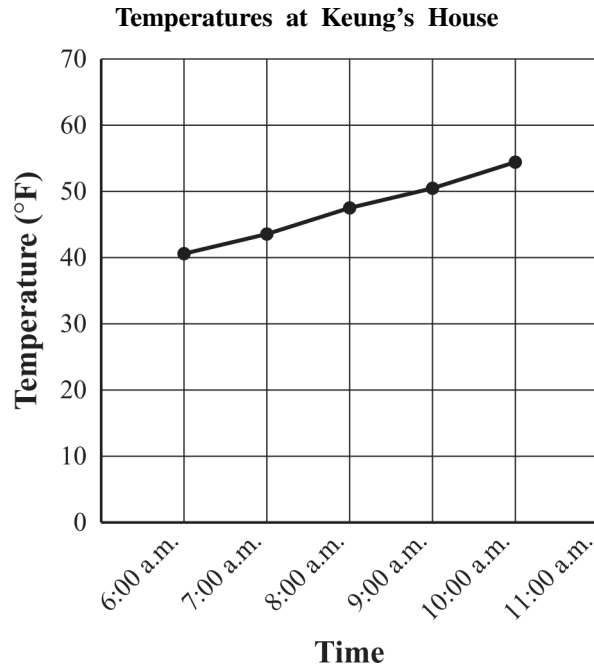

Based on the graph, what will the temperature at Keung’s house *most likely* be at 11:00 am?

- A. 48°F B. 52°F C. 58°F D. 65°F

45. The scatterplot below shows the relationship between the number of minutes available for a cell phone plan and the monthly cost, in dollars, of different cell phone plans.

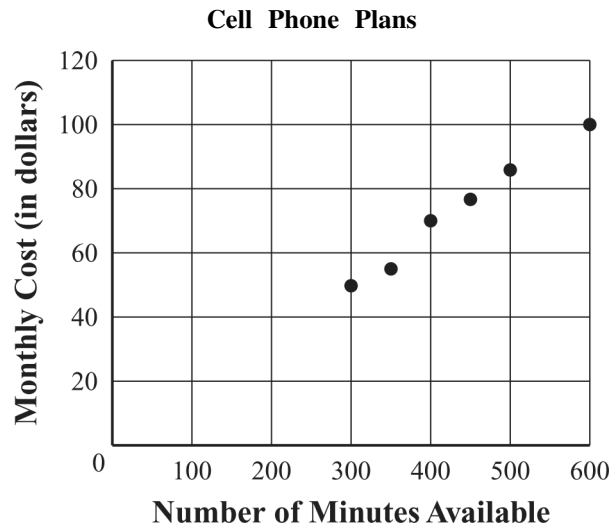

Based on the line of best fit for the scatterplot, what is the expected number of minutes available for a cell phone plan that has a monthly cost of \$40?

- A. 150 B. 250 C. 350 D. 450

46.

The Scale shown below is balanced.

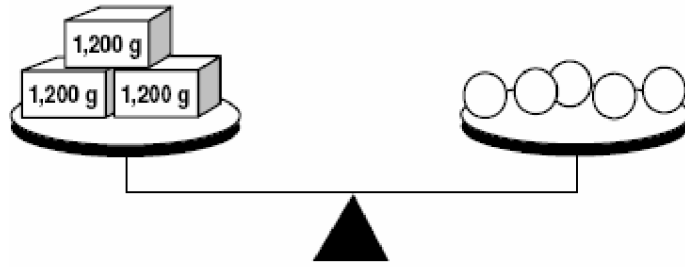

Each of the balls on the right side of the scale weight of each ball?

- A. 600 g B. 720 g C. 900 g D. 1,200 g

47. If $\triangle \triangle + \bullet = \bullet \bullet \bullet \bullet \bullet$

Then

- A. $\triangle = \bullet \bullet \bullet \bullet \bullet \bullet$ B. $\triangle = \bullet \bullet \bullet \bullet$
C. $\triangle = \bullet \bullet \bullet$ D. $\triangle = \bullet \bullet$

48. Callie balances a scale by placing apples and a $\frac{1}{2}$ -pound weight on one side of the scale and two 1-pound weights on the other side.

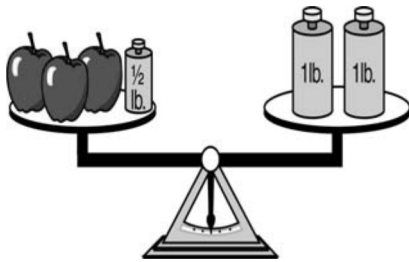

If each apple weighs approximately the same amount, about how much does one apple weigh?

- A. 0.50 pound B. 0.67 pound C. 0.75 pound D. 0.83 pound

49. Use the picture below to answer the following question.

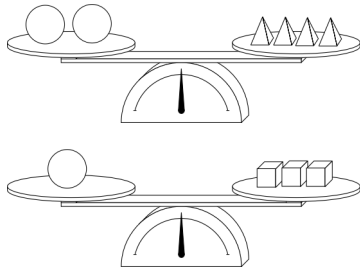

If the scales shown above are balanced, then which scale below is also balanced?

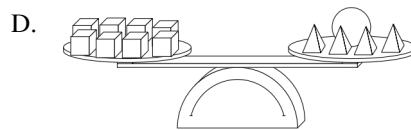
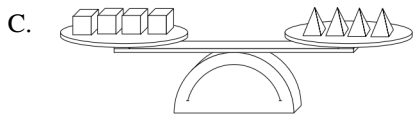
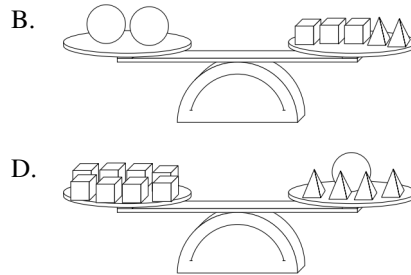
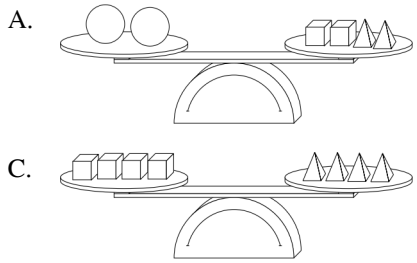

50. Both of the scales shown below are balanced.

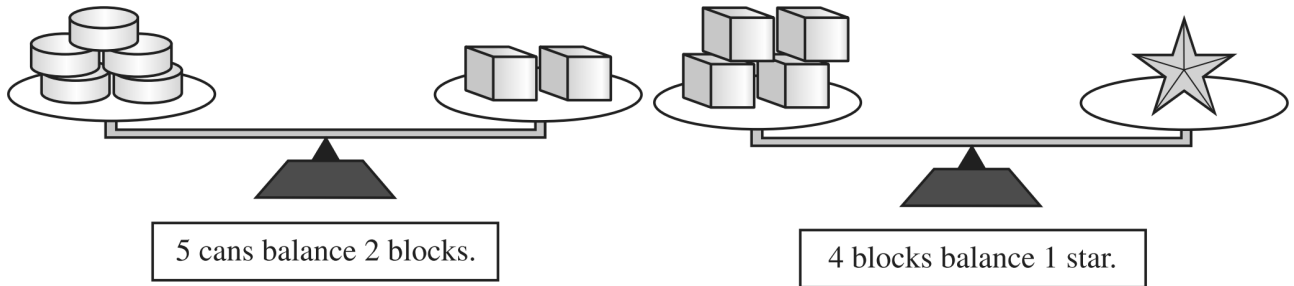

How many cans are needed to balance 1 star?

51. The scale shown below is balanced. Each \triangle has the same weight, and each \ominus has the same weight.

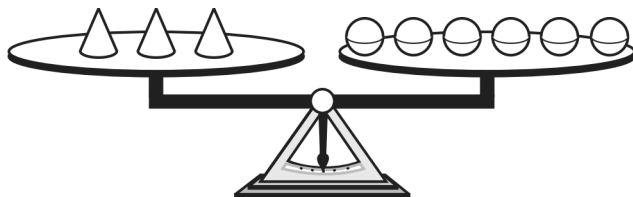



How many \ominus are needed to balance five \triangle ?

A. 10

B. 11







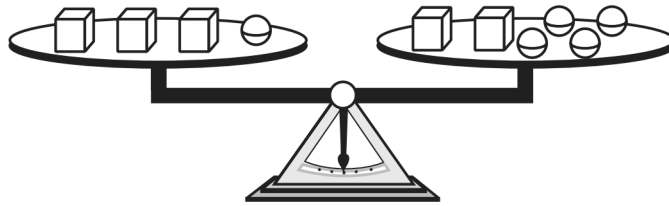







C. 15

D. 18

52. The diagram below shows a scale that is balanced. Each  has the same weight, and each  has the same weight.

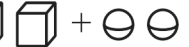



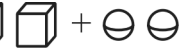



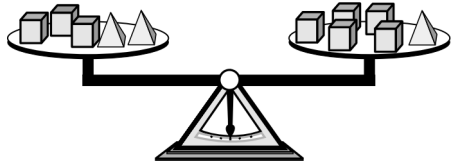

Based on the diagram, which of the following is true?

- A.  +  =  + 
- B.  +  >  + 
- C.  +  =  + 
- D.  +  >  + 

53. Use the picture of the balance scale below to answer the following question(s).



Which sentence is true based on the balance shown by the scale?

- A. The weight of  is the same as the weight of .
- B. The weight of  is the same as the weight of .
- C. The weight of  is the same as the weight of .
- D. The weight of  is the same as the weight of .

54. Maxine's homework assignment is to determine the value of n that makes the equation below true.

$$26 + n = 78$$

Which of the following equations could Maxine use to determine the value of n ?

- A. $78 - 26 = n$ B. $78 + 26 = n$ C. $26 - 78 = n$ D. $26 + 78 = n$

55. Use the balance scales below to answer the question.

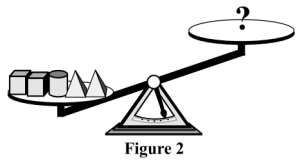
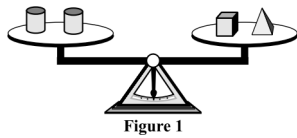

How many cylinders must be placed on the empty side of the second scale to make that scale balance?

- A. 5 B. 2 C. 3 D. 4

56. The scale shown below is balanced.

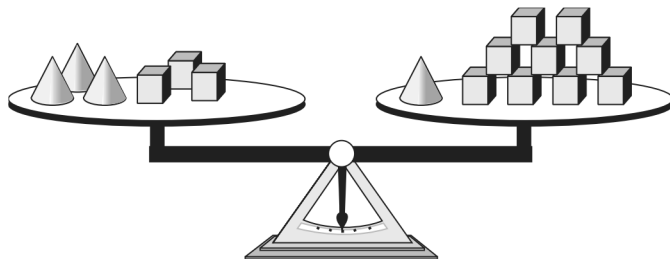

How many cubes will it take to balance one cone?

- A. 3 B. 4 C. 5 D. 6

57. The objects on each side of the balance have exactly the same total mass.

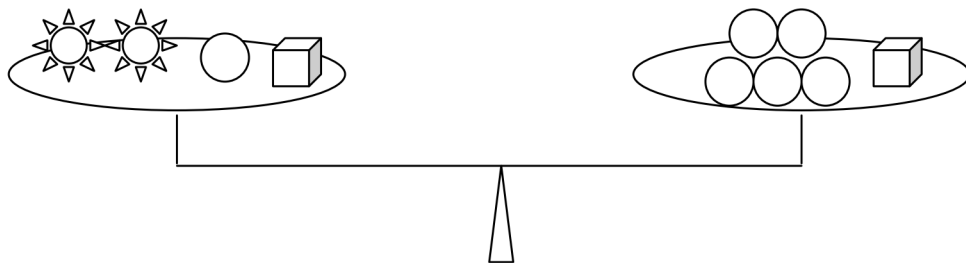

Which does the  balance?

- A.  B.   C.   D.   

58. The scale shown below is balanced.

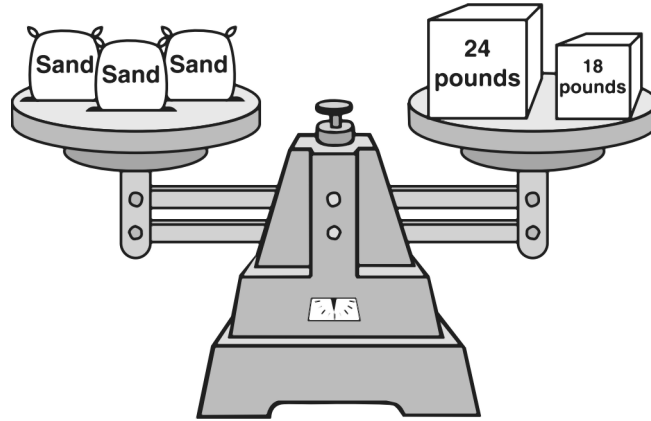

Each bag of sand weighs the same. How many pounds does one bag of sand weigh? Show your work or explain how you know.

59. The number machine shown below uses a rule to change each number that is put into it to a different number. The same rule is used every time.

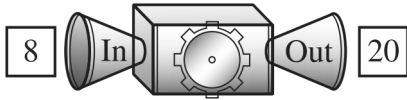

The table below shows what happened when three different numbers went into the same number machine.

In	Out
8	20
5	14
12	28

Which of the following could be the rule used by this number machine?

- A. add 12
- B. add 24
- C. multiply by 2, then add 4 to the result
- D. multiply by 3, then subtract 4 from the result

60. Kareem made the input-output table shown below.

Input	Output
1	4
2	9
3	14
4	19

Which of the following could be the rule for Kareem's input-output table?

- A. Add 3 to the input to get the output.
- B. Add 5 to the input to get the output.
- C. Multiply the input by 3, and then add 1 to the result to get the output.
- D. Multiply the input by 5, and then subtract 1 from the result to get the output.

61. The first five terms of a pattern are shown below. The rule of the pattern is to multiply by 2 and then subtract 1.

4, 8, 7, 14, 13, ...

What should be the seventh term of this pattern?

- A. 13 B. 14 C. 25 D. 50

62. Sam began a pattern with 4 and 7. He added them to get 11, the third term. To get each term after the third, he added the two preceding terms.

4, 7, 11, 18, 29, ...

What is the 9th number in this sequence?

- A. 47 B. 123 C. 199 D. 322

63. Use the chart below to answer the question that follows.

Puppy's Age	Puppy's Weight
1 month	10 lbs.
2 months	15 lbs.
3 months	19 lbs.
4 months	22 lbs.
5 months	?

John records the weight of his puppy every month in a chart like the one shown above. If the pattern of the puppy's weight gain continues, how many pounds will the puppy weigh at 5 months?

- A. 30 B. 27 C. 25 D. 24

64. Find the next two terms in the sequence shown below.

1, 3, 7, 15, 31, ? , ?

- A. 53, 117 B. 63, 127 C. 73, 137 D. 83, 147

65. Cindy wrote a number pattern using the rule below.

- The first number in the pattern is 3.
- To find the next number in the pattern, add 1 to the previous number and then double the sum.

What is the fourth number in the pattern?

- A. 13 B. 18 C. 31 D. 38

66. The chart shows the greatest number of line segments that can connect various numbers of points on a circle.

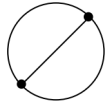
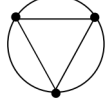
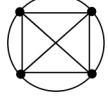
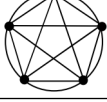
Figure	Number of Points	Number of Line Segments
	2	1
	3	3
	4	6
	5	10

Based on the number pattern, how many line segments will connect 8 points?

- A. 16 B. 21 C. 25 D. 28

67. If this pattern continues, what is the next number?

5, 8, 7, 10, 9, 12, 11

- A. 14 B. 13 C. 12 D. 10

68. Look at this schedule of interview times.

Schedule

Interview	Time
1st	1:00
2nd	1:40
3rd	2:20
4th	3:00

If the pattern continues, at what time is the 5th interview?

- A. 3:20 B. 3:40 C. 4:00 D. 4:20

69. Look at this pattern of shapes.

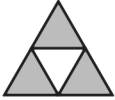
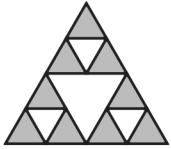
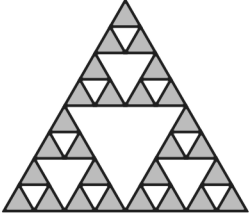
Figure		Number of Shaded Triangles
1		1
2		3
3		9
4		27

The pattern continues. How many shaded triangles will be in Figure 5?

- A. 36 B. 81 C. 243 D. 729

70. Which graph could represent the situation below?

Ryan skateboards down a ramp, skateboards up the other side, and skateboards back down.

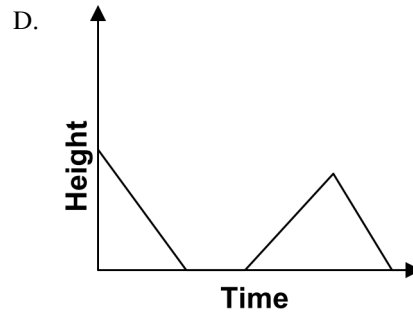
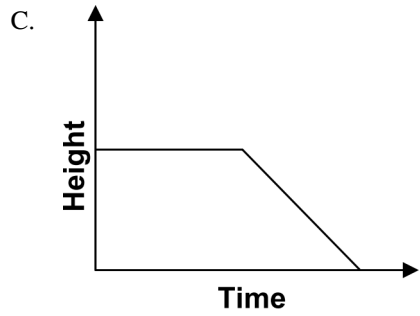
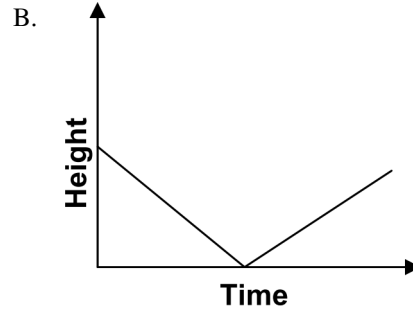
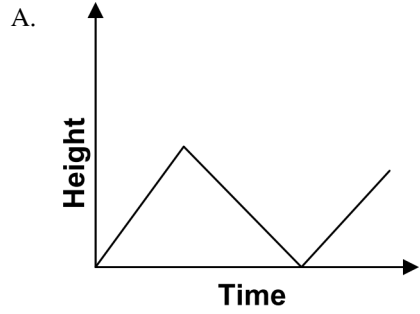

71. Kendra is observing how the height of a tall, thin cylindrical candle changes over time as it burns.

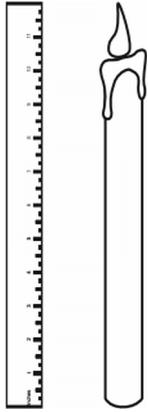

Which graph best represents the changes in the height of the candle over time?

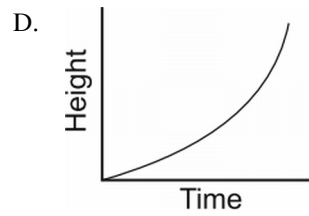
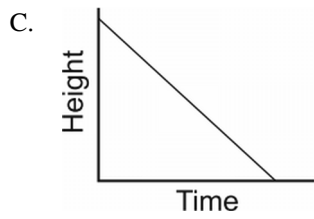
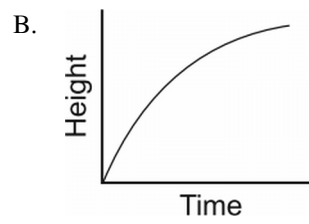
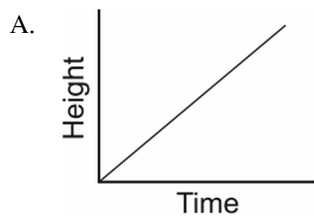

72. Look at this graph.

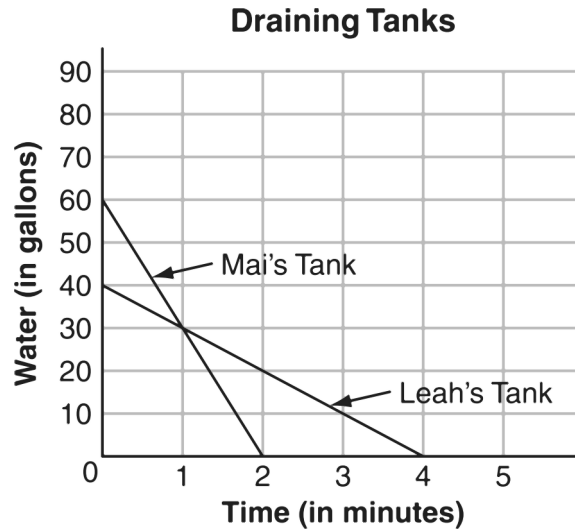

Mai and Leah drain two tanks of water. The graph shows the amount of water in each tank as it drains. Which statement below is true?

- A. Mai's tank always has more water in it than Leah's tank.
- B. Leah's tank always has more water in it than Mai's tank.
- C. Mai's tank drains faster than Leah's tank.
- D. Leah's tank drains faster than Mai's tank.

73. Which of these *best* describes the rule for the x and y values in the table below?

Input (x)	Output (y)
6	14
7	17
8	20
9	23
10	26

- A. $3x - 4 = y$
- B. $2x - 4 = y$
- C. $3x + 4 = y$
- D. $2x + 4 = y$

74. Which expression describes the rule used in the input/output model below?

Input (x)	9	21	30	3	45	12	27	6
Output (y)	5	9	12	3	17	6	11	4

- A. $x \cdot 2 - 3 = y$
- B. $x \cdot 3 + 2 = y$
- C. $x \div 2 - 3 = y$
- D. $x \div 3 + 2 = y$

75. A tree farm charges \$75.00 for a 5-foot orange tree and \$50.00 for delivery regardless of the number of trees purchased. Which equation expresses the total cost, C , in terms of the number of 5-foot trees, t , purchased?
- A. $C = 75 + 50t$ B. $C = 75t + 50$ C. $C = 75t + 5$ D. $C = 75 + 5t$

76. The following table represents C , an appliance repairman's charges based on t , the hours it takes to make a repair.

**APPLIANCE REPAIR
TOTAL CHARGES**

t (hours)	C (dollars)
1	75
3	145
5	215
7	285

Which of the following equations could be used to determine the repairman's charges for a repair?

- A. $C = 35t + 40$ B. $C = 40t + 35$ C. $C = 75t$ D. $C = 45t$
77. The rectangle shown below has length 15 inches and perimeter P inches.

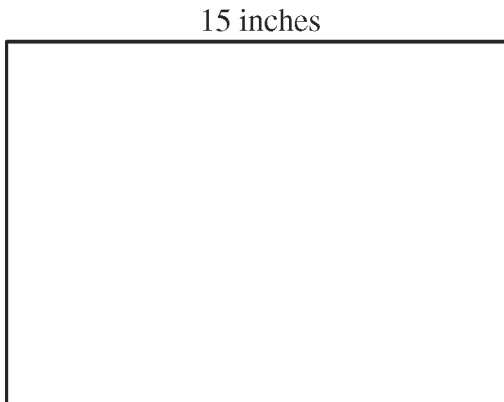

Which equation could be used to find the width of the rectangle?

- A. $P = 15 + \frac{w}{2}$ B. $P = 15 - w$ C. $P = 30 + 2w$ D. $P = 30 - 2w$
78. A relationship is shown in the table below.

x	y
1	2
2	5
3	8
4	11

Which rule represents this relationship?

- A. $y = 2x$ B. $y = x + 1$ C. $y = 3x - 1$ D. $y = 3x + 2$

